



Assist.Prof. Dr. Muhanad Rasheed

Al-Rasheed University College
DEP. OF MEDICAL INSTRUMENTATION TECHNIQUES ENGINEERING

Lecture 10 : Receiver devices and circuits photodiode light detector

1. An optical receiver, sometimes called a fiber optic receiver, is a component in a fiber optic network that is a system in which some parameter of an optical signal is modulated in a reproducible and recoverable manner by a measuring component. **In other words the role of the receiver is to translate pulses of light that are sent through optical fibers into electrical signals.** ... This device translates the pulses of light into a series of ones and zeros, called binary code.
2. It is necessary to convert the optical signal to an electrical one in order that it may be processed and either recorded or displayed. This function is accomplished using a photo-detector, which converts optical energy to electrical energy. The photo-detector generally produces only a low level electrical signal, which must immediately be amplified before it can undergo further processing. **The combination of a photo-detector and its immediate amplification + (equalizer) is called a receiver.**
After the optical detector converts the incoming optical signal into an electrical signal, the amplifier increases it to a level suitable for additional signal processing.
3. Fiber optic receivers convert light signals into electrical signals for use by equipment such as computer networks or medical systems

. The modulation type and the electrical output requirements determine what other circuitry is required.

4. Fiber optic receivers use positive-negative junctions (PN) photodiodes as optical detectors. The incoming light signal is sent by a fiber optic transmitter (or transceiver) and travels along single-mode or multi-mode optical cable . A data demodulator converts the light signal back into its original electrical form.

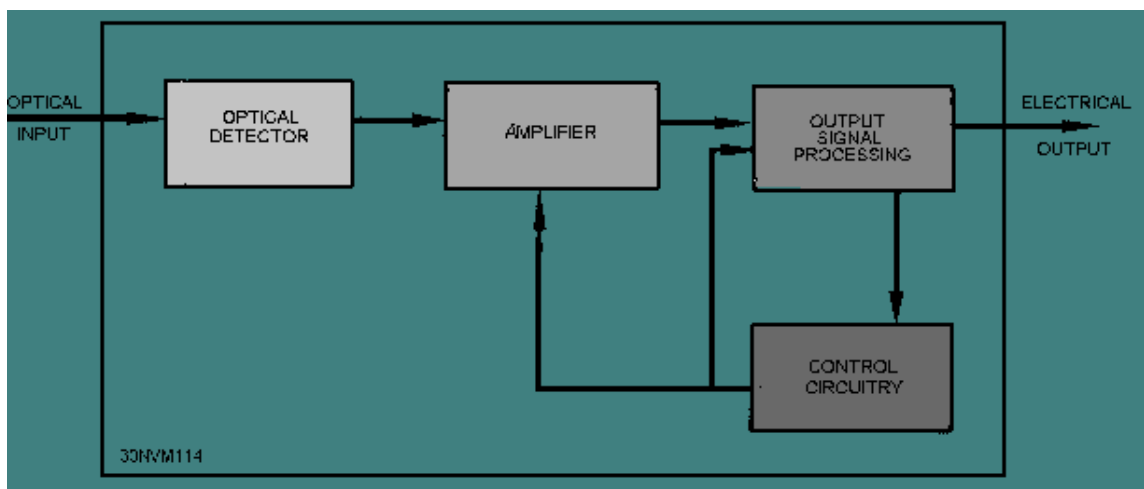

Fiber Optic Receiver Block Diagram

5. Receiver Performance

For fiber optic receiver performance , these points must be noticed

- **Data rate** is the number of bits transmitted per second, and is an expression of speed.
- **Receiver rise time** is also an expression of speed, but indicates the time required for a signal to change from a specified 10% to 90% power.
- **Sensitivity** indicates the weakest optical signal that the device can receive.

❖ To summarize the components of the receiver mentioned above .. the receiver consists of :

1. The photo-detector (optical detector): PN photodiode.
2. Low-noise amplifier
3. Signal conditioning circuitry : e.g. equalizer which is a linear frequency shaping filter that is used to soften the effects of signal distortion .

❖ An optical amplifier is a **device that amplifies an optical signal directly**, without the need to first convert it to an electrical signal.

❖ **Fiber optic receiver** is shown in Figure below:

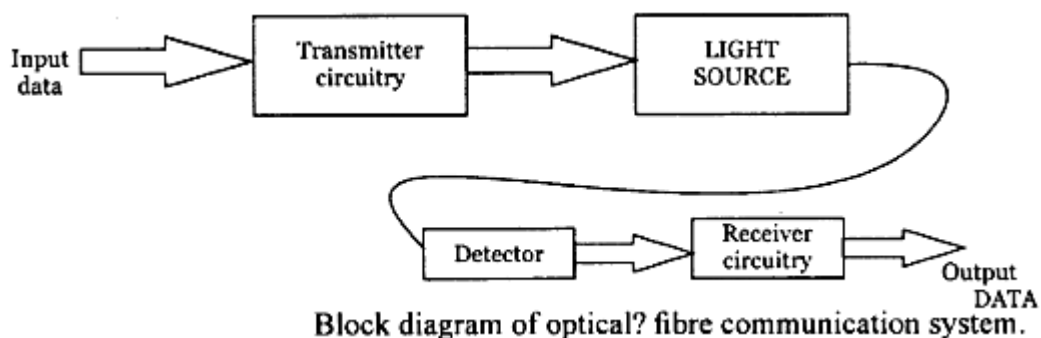

❖ The heart of an optical receiver is the **photodiode**, which has an output current proportional to the light power impinging on the diode.